

## TA09 Tile Anchor

Available in 450 mm and 650  
mm sizes

*RA-20 Over Ridge  
Anchor is available  
with a D-ring on  
both ends (not shown)*



## Product Description

A surface mounted stainless steel roof anchor to suit a appropriate clay and concrete tiles, various forms of slate and faux slate and timber and asphalt shingle roofing providing height safety in fall arrest and restraint applications.

### LIMITATIONS:

The anchor is rated to 21kN but not to be utilised by more than one person and as such, not be subject to a load of more than 15kN in accordance with AS/NZS 1891.4 (Table 3.1). At no stage must the worker subject to the anchor, any loads from above the TA09 on the roof plane. The anchor can only ensure fall restraint/arrest in a downward direction, ie. **WORK BELOW THE ANCHOR AT ALL TIMES!** Do not work in a fashion that will apply a an arresting load perpendicular to the 'TA09.

### APPLICABLE STANDARDS:

Australian/New Zealand Standard 1891.4



## Technical Data

(Please specify application to ensure correct screw fixings are supplied)

Weight (approx): 350 Grams (without fixings)  
Dimensions (overall): 450mm x 50mm x 8mm nominal  
Screw Fixings – Tile: 6 off M6x50mm Hex Head HG Seal C4 Roof Zips

Screw Fixings:  
– Single/Slate/Wood: 6 off 75mm Stainless Steel Screws

### COMPOSITION AND MATERIALS:

The TA09 is composed of 304 Stainless Steel in mill finish with a stainless steel D-Ring.

## Maintenance

The TA09 should be checked annually at the very least by a 'competent' person as required and/or detailed in Government OH&S Acts, Codes of Practice and all applicable building codes. The TA09 Tile/Slate and Shingle Anchor must also be checked prior to any attachment or use ensuring that the anchor has not been subject to any fall loads nor that it has been tampered with. Ensure that the TA09 is firmly attached to the rafter and not loose with the use of all screw fixings as detailed in 4. Technical Data above and the illustration following. Ensure all safety equipment to be used in conjunction with the TA09 is checked prior to use.

**Distribution by:**  
**Shingles Supply Pty Ltd**  
Australia & International  
Order: 1300 131 881  
Enquires: +61 2 9317 3553  
PO Box 1346 Moss Vale NSW 2577  
[shinglessupply.com.au](http://shinglessupply.com.au)



## Fixing Diagram

(To be read in  
conjunction  
with installation  
instructions below)

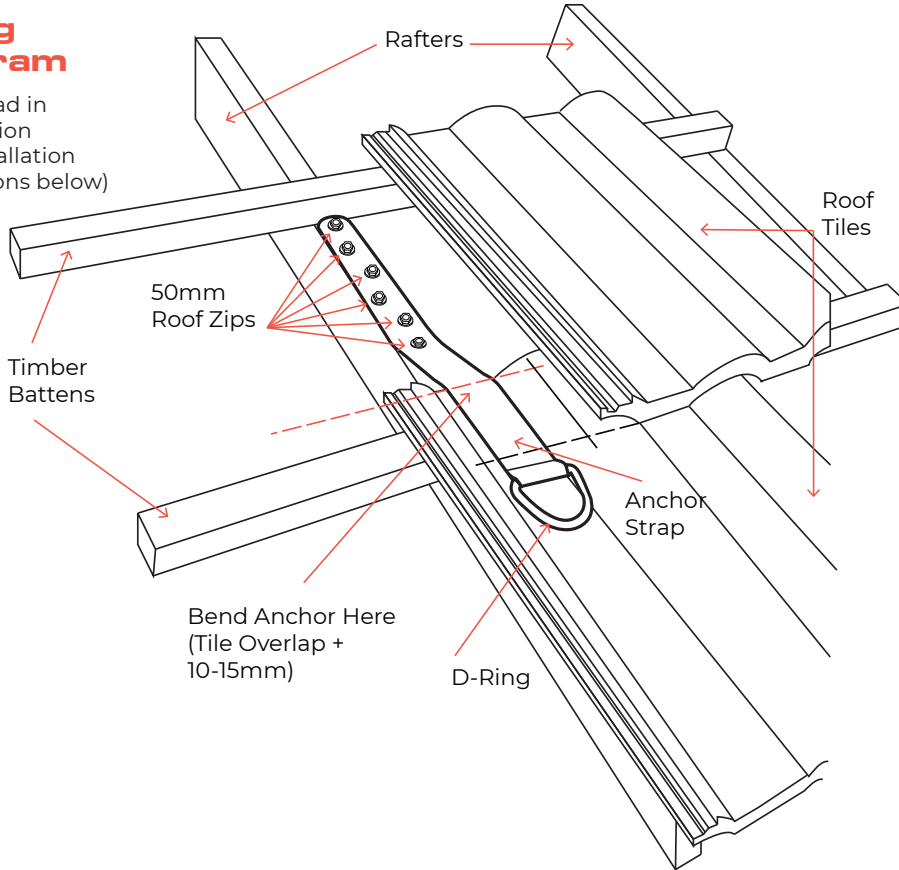

## FIXING NOTES:

- Bend the anchor strap greater than the pitch of the roof by the distance of the overlap + 15mm from the rear of the D ring
- Place the anchor with the strap centred over a rafter with the bend at the rear of the tile it is going to sit upon.
- Push the strap down against the rafter and fix the roof zips in place from the second screw hole from the bottom of the anchor
- Place the last and sixth screw in the bottom hole closest to the D ring. The strap will not sit flat to the rafter at this point
- Ensure that all screws are firmly fixed but NOT overtightened with all washers intact under the heads of the screws

## Installation Instructions

Following is a general summary of the installation method. If there is any doubt or non surety as to the application of this anchor in accordance with these instructions please contact Secure Anchor Systems.

### ROOF REQUIREMENTS:

Apply the TA09 to a Tile/Slate or Shingle roof fixed in accordance with the manufacturer's instructions, all applicable building codes and Australian Standards. The rafter or structural member must be adequately strong enough to withstand 15kN of load.

### APPLICATION & FASTENING:

Six (6) screws are required to be used on the TA09 roof anchor. Two holes are centred on the anchor, one at the top and one at the bottom with two pairs of holes running down of the stem and off set to each other. The M6 x 50mm Roof Zips are required to be fastened through all holes into a rafter that has a minimum strength grade of MGPI0.

Bend the anchor to an angle greater than the roof pitch at a distance no less than the tile overlap + 15mm. This will enable to anchor to sit snugly and push down on the tile that it sits upon. Place the anchor over and centred on a rafter with the bend at the rear of the tile. Apply pressure and push the anchor strap against the rafter maintaining the bend at the rear of the tile. Fix the first roof zip in the second hole from the bottom of the anchor. Fix the screw firmly in place ensuring that the anchor is centred over the rafter. Fix the second screw in the top hole and then fill the remaining three screw in between. Ensure the screws are firmly fixed but not overtightened.

Fix the last and remaining screw in the bottom hole closest to the D Ring. As the strap will curve up from the rafter to bridge the difference in height of the thickness of the tile and the batten, this screw must be fixed without screwing flat to the rafter. Screw the roof Zip down to the face of the strap without it pulling the D Ring off the tile. If this happens, release the screw to allow the D Ring to sit flat on the tile. Place the overlapping tile back over the anchor and nibble off the lip on the underside of the tile to

the width of the strap of the anchor. This will allow the tile to sit flat on the anchor and the underlying tile. If there is a risk of wind driven water being blown up under the tile, a bead of sealant may be placed on the bottom edge of the tile to prevent this from occurring.

### FLASHING:

The TA09 requires no additional flashings.

*Secure Anchor Systems recommends that all anchor installers & users be 'competent' in accordance with AS 1891, relevant Codes of Practice and applicable OH&S acts in your state.*

*Secure Anchor Systems always recommends placement of anchors using a 'fall restraint' methodology and working in a 'fall restraint' mode when working at heights.*

### Distribution by:

**Shingles Supply Pty Ltd**

Australia & International

Order: 1300 131 881

Enquires: +61 2 9317 3553

PO Box 1346 Moss Vale NSW 2577

[shinglessupply.com.au](http://shinglessupply.com.au)



**SHINGLES  
SUPPLY**

Roofing products & safety equipment